

- ◆ Designed for DAS covering all wireless bands to 5.85 GHz
- ◆ 10W avg. Power Divider
- ◆ Low RF Insertion Loss
- ◆ High Isolation
- ◆ RoHS compliant
- ◆ Rugged and Reliable Design
- ◆ Opposed 4.3-10, N, & SMA Connectors for ease of installation



Model D2-49FE

This Dx-49 series of 2 & 4 way Wilkinson style Power Dividers cover the ultra broad band of 350 - 5850 MHz using a multi-section microstrip design.

The broad bandwidth and output isolation of this product can eliminate the need for multiple cable paths in the design of distributed antenna systems.

Impedance:	50Ω nominal
Power, as divider:	10W avg., (Load VSWR<1.2:1)
Power, as combiner:	100mW max. average per port
Environment:	-50° to +70°C, IP64 (IP67 to order)
Finish: Connectors:	4.3-10(f), N(f), and SMA(f), triplate
Housing:	Passivated aluminum
Weight 2-Way:	16 oz (455g)
4-Way:	28 oz (800g)

4.3-10	Model		Frequency Range MHz	No. of Ways	Split Loss nom	Isolation dB min	Dissipative Loss dB max	Output Balance		VSWR [‡]	
	N Type	SMA						Amplitude typ.	Phase typ.	Input max	Output max
D2-49FE	D2-49FN	D2-49FF	350 - 5000	2	3	>20	<0.9	0.2 dB	10°	1.40:1	1.30:1
			5000 - 5850								1.40:1
	D4-49FN	D4-49FF	500 - 5000	4	6	>20 [†]	<1.0	0.5 dB	-	1.40:1	1.30:1
			350 - 5850			>14	<1.5				1.40:1
*model in development			†>18dB isolation on D4-49FF			‡VSWR: <1.45:1 (in) / <1.40:1 (out) on D4-49FF					

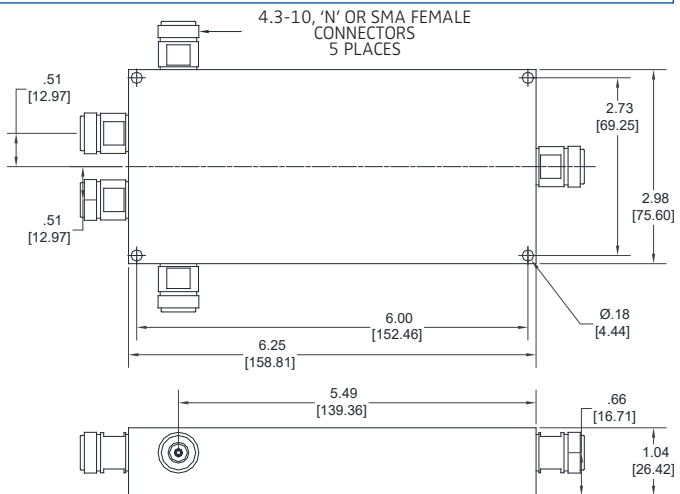
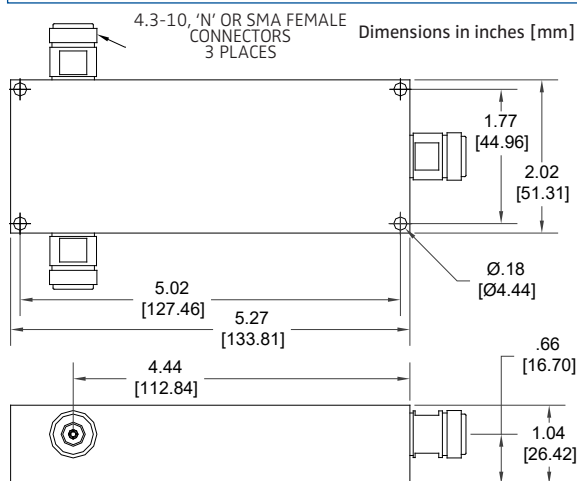

Note: Specifications are subject to change without prior notification.

29MAR2018