



DCC521 HPOI

DCR Broadband Base Unit

Microlab DCC521 Series is a multi-band High Power Point of Interface (HPOI) Module. It operates over the 850 MHz and 1900 MHz cellular bands. The HPOI is used with the DAS Control Rack (DCR) to monitor and control power levels in the DAS head end. The HPOI separates the duplexed signals from the base station and attenuates the high powered signal to a level acceptable to the DCR.

Microlab DCC Series® products are built on a common platform that provides a high level of customization for your particular application. The HPOI Trays are available in different input power ranges to accommodate different BTS transmit powers. Connector types and locations make it convenient for installation. Microlab has developed a wide variety of standard HPOIs, which can quickly be installed in conjunction with a standard DCR into the perfect custom monitor and/or attenuation system solution. Rack mid-mount kit and flexible SMA cables to connect the HPOI to the DCR included.

HPOI MODELS* (Other Band and Band Combinations are available)				
Power Input Tx	850 + 1900 MHz	Insertion Loss Tx	EIA Rack Height	PIM Test Power Levels
60 W	DCC521-A48[C/D/E] [B/F]	31 dB	2 RU	2 x 43 dBm
5 W	DCC521-A37[C/D/E] [B/F]	21 dB	2 RU	2 x 34 dBm
*Add BTS connector designator to end of model #: C for 4.1-9.5 DIN, D for 7-16 DIN, E for 4.3-10 Location of BTS connector is designated by B for back or F for front panel				

Common Specifications	
Frequency Band 850 MHz Band (2 ports)	Tx: 869-896 MHz Rx: 824-851 MHz
1900 MHz Band (2 ports)	Tx: 1930-1995 MHz Rx: 1850-1915 MHz
Rx Insertion Loss	2 dB
Tx Isolation (Tx/RX)	>60 dB
PIM (Intermod) 2 x +43 dBm tones: 2 x +34 dBm tones:	<-154 dBc, -156 dBc typ <-145 dBc, -147 dBc typ
Impedance	50 Ω nominal
Connector Type Input: Output:	4.1-9.5, 7-16 or 4.3-10 SMA
Environment	0-50 °C / 32-131°F
Size	19" W x 17" D

DCR Models	Description
DCC500-A01	4 channel low power Active DAS tray with power monitoring and attenuation control, 110-250 VAC power supply.
DCC500-B01	4 channel low power Active DAS tray with power monitoring and attenuation control, -48/+24 VDC power supply
DCC550-A01	12 channel power monitoring only DAS Tray
DCC560-A01	4 channel attenuation control only DAS Tray

Application of DCC521 in DAS:

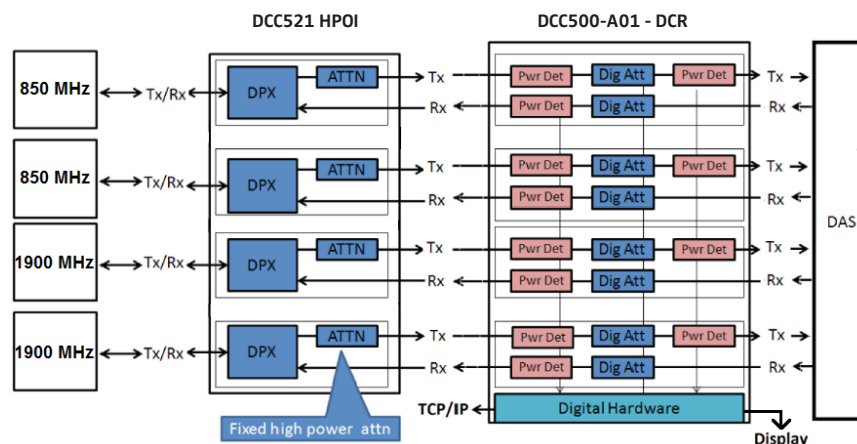

Note: Specifications are subject to change without prior notification.

28SEP2015